



**SAINT JOHN
HERITAGE
DEVELOPMENT
BOARD**

AGENDA

JANUARY 22, 2014

**CONSEIL
D'AMÉNAGEMENT
DU PATRIMOINE
DE SAINT JOHN**

ORDRE DU JOUR

LE 22 JANVIER, 2014



**The City of Saint John
Heritage Development Board**

AGENDA

**Wednesday January 22, 2014
Le 22 janvier, 2014**

**5:30 P.M. - 10th floor Board Room
à 5 h 30 dans la salle de conférence, au 10^e étage**

- 1.0 Approval of Agenda/Adoption de l'ordre du jour
- 2.0 Approval of Minutes/Approbation du procès-verbal de la dernière réunion
 - 2.1 December 11th, 2013 Meeting Minutes
- 3.0 Business Arising/Revue de la dernière réunion
 - 3.1 Introduction of new Board member: Bob McVicar
 - 3.2 Update on Heritage Grant Program
 - 3.3 2014 Heritage Grant Funding Model
- 4.0 Introduction of Applicants/Guests/Présentation des requérants et des invités
- 5.0 Applications for Certificates of Appropriateness and Grants/
Demandes relatives à des certificats de pertinence de à des subventions
 - 5.1 Bob McVicar, 77 Orange Street 14-01
 - a) Application for Certificate of Appropriateness
 - b) Draft Certificate of Appropriateness
 - c) Application for Heritage Conservation Grant
 - 5.2 Bob McVicar, 78 Orange Street 14-02
 - a) Application for Certificate of Appropriateness
 - b) Draft Certificate of Appropriateness
 - c) Application for Heritage Conservation Grant
- 6.0 Reports/ Rappports
- 7.0 Other Business/Autre affaires
- 8.0 Next Meeting/Prochaine reunion
- 9.0 Adjournment/Clôture de la réunion



**HERITAGE DEVELOPMENT BOARD
OF
THE CITY OF SAINT JOHN**

WEDNESDAY DECEMBER 11TH, 2013

The meeting of the Heritage Development Board was held in the 10th Floor Boardroom of City Hall, commencing at 5:00 pm.

IN ATTENDANCE:

Leona Laracey, Chair
Gordon Hewitt, 1st Vice Chair
Patrick McCaffrey, 2nd Vice Chair
Councillor Donna Reardon
Scott Rinehart
Bob Boyce
Colin Waldschutz
Elizabeth McGahan
Alex Pesold

Jill Good, Recording Secretary
Alice Fudge, Heritage Officer
Amy Poffenroth, Deputy Commissioner

REGRETS:

ITEM 1.0 AGENDA

The following item was added to the agenda under Other Business:

Item 3.2 Demolition of Heritage Assets
Item 3.3 Cathedral

***MOVED** by Elizabeth McGahan, **SECONDED** by Scott Rinehart to approve the agenda as amended.*

CARRIED.

ITEM 2.0 MINUTES

ITEM 2.1 MINUTES OF THE NOVEMBER 27TH, 2013 MEETING

***MOVED** by Gord Hewitt **SECONDED** by Scott Rinehart to approve the November 27th, 2013 minutes as circulated.*

CARRIED.

ITEM 3.0 BUSINESS ARISING

ITEM 3.1 ELECTION OF OFFICERS

Chair

Leona Laracey assumed the position of Board Secretary as outgoing Chair and called for nominations for the position of Chair. Bob Boyce was nominated for the position, and nominations were called for three times. There being no further nominations, nominations ceased, Bob Boyce accepted the nomination.

Bob Boyce was declared Chair.

1st Vice Chair

Leona Laracey called for nominations for the position of Vice Chair. Patrick McCaffrey was nominated. Nominations were called for three times. There being no further nominations, nominations ceased. Patrick McCaffrey accepted the nomination.

Patrick McCaffrey was declared 1st Vice Chair.

2nd Vice Chair

Leona Laracey called for nominations for the position of 2nd Vice Chair. Elizabeth McGahan was nominated. Nominations were called for three times. There being no further nominations, nominations ceased. Elizabeth McGahan accepted the nomination.

Elizabeth McGahan was declared 2nd Vice Chair.

ITEM 3.2 UPDATE ON 100 WATSON STREET & 183 DUKE STREET WEST

Heritage Officer, Alice Fudge advised that the public hearing for 100 Watson Street & 183 Duke Street West with regards to the request for removal from the King Street West Heritage Conservation area, has been postponed until February 3, 2014. She advised that the applicant Susan Jack has been notified of the change of date.

ITEM 4.0 INTRODUCTION OF APPLICANTS/GUESTS

There were no guests present.

ITEM 5.0 CERTIFICATES OF APPROPRIATENESS AND GRANTS

There were no applications.

ITEM 6.0 REPORTS

There were no reports.

ITEM 7.0 OTHER BUSINESS**ITEM 7.1 UPDATE ON THE 2013 HERITAGE GRANTS**

Alice Fudge provided the Board with an update on the total amount of grant funding disbursed this year. There were a total of 37 grants conditionally approved this year, 21 submissions and 19 grants approved, for a total of \$26,812.70 in grant funding to be released.

In October there was a letter mailed out to all conditionally approved applicants reminding them of the November 29th deadline for submission as well as information outlining the program and what paperwork was required.

The Board expressed their concerns in the decrease in the total of submissions, but were very pleased with the quality of work completed and staff relayed that of those submitted they were complete, proper and made on time. Board members requested that staff review the remaining applications and determine if the decrease in submissions could be related to a decrease in overall economic activity, projects not being completed, public perception, shortage of staff, decrease in total grant funding etc. Board members and staff agreed that it was important to understand the reasons for the decrease in applications. Leona Laracey requested that staff and Board members review a report that had been prepared in 2008 by the Wright Agency entitled "Saint John Heritage Awareness Plan"

Amy Poffenroth advised that in the next month, staff would be reviewing the current funding ratios and the report from Deloitte concerning the Heritage Grant program and administrative process improvements and that a report would be brought to the Board for the January 22nd, 2014 meeting. Ms. Poffenroth advised that staff would be bringing forth a new grant policy and changes to our current process in the New Year and she recommended that grant applications in early 2014 be tabled until the process is put in place.

ITEM 7.2 CATHEDRAL OF THE IMMACULATE CONCEPTION, 91 WATERLOO STREET

Alice Fudge advised the Board that she has received correspondence from Gilles Bourque, Acting Manager of Historic Places Section for the Province of New Brunswick on November 20th, 2013 that the Cathedral at 91 Waterloo Street be designated as a provincial heritage place. Ms. Fudge advised that there was a 30 day period during which time the public can submit their objections to the designation of the property. Board members did not express any objection.

ITEM 7.3 UPDATE ON 115 PRINCE WILLIAM STREET

Alice Fudge provided the Board with an update that the property at 115 Prince William Street has been sold. She has been contacted by the architect hired by the new owners, and it is their intention to create luxury apartment units. Ms. Fudge advised that while the majority of the renovations will be interior, there will be minor repairs to the exterior that may see an application for a Certificate of Appropriateness before the Board in the New Year.

ITEM 7.4 MEMORANDUM: ABC's & RTIPPA

A memorandum concerning the general guidance to local boards of the City of Saint John regarding their obligations under the *Right to Information and Protection of Privacy Act*, from David Burke, Access & Privacy Officer was received and filed by the Board.

ITEM 8.0 NEXT MEETING

The next regular Board meeting will be held January 8th, 2014

ITEM 9.0 ADJOURNMENT

There being no further business, the meeting adjourned at 6:10 p.m.

Amy Poffenroth, P.Eng, MBA
Deputy Commissioner,
Growth & Community Development Services



The City of Saint John

**APPLICATION FOR A HERITAGE PERMIT
[CERTIFICATE OF APPROPRIATENESS]
2014-01**

**C/O: BOB McVICAR
77 ORANGE STREET
(PID 00007740)**

Date: January 17th, 2014

To: Heritage Development Board

From: Growth and Community Development Service

Prepared by: Alice C. Fudge
Heritage Officer

Approved by: Amy Poffenroth, P.Eng, MBA
Deputy Commissioner

SUBJECT

Application for a Heritage Permit [Certificate for Appropriateness] to install two new steel hand railings, painted black, on front entrance stair.

BACKGROUND

This four-storey brick residential building is located in the Orange Street Conservation Area; there is a Conservation Plan in place for this property.

To meet the Minimum Property Standards By-Law requirements, two hand rails must be installed at front entrance on either side of the sandstone steps for safety purposes.



SAINT JOHN

P.O. Box 1971
Saint John, NB
Canada E2L 4L1

C.P. 1971
Saint John, N.-B.
Canada E2L 4L1

www.saintjohn.ca

1

ANALYSIS

This is a Rehabilitation project and Standards I through XII of Section 8(2) of the *Saint John Heritage Conservation Areas By-law* apply. The proposed hand railings address the safety concerns of the owner and serve to rehabilitate the building.

Where a new element is introduced, Standard (XI) recommends that such a new addition to a historic place conserve its heritage value and character-defining elements and be visually compatible and respectful of the historic place. The materials and traditional design of the railings meet this standard. The steel rails are to be painted black. The railing post base plates shall be fixed to the stair treads by set-in-place bolts.

Standard (I) recommends that all intact or repairable character-defining elements be conserved.

RECOMENDATION

Approve Heritage Permit [Certificate of Appropriateness] for the installation of two new steel hand railings, painted black, on front entrance stair of 77 Orange Street.

MARK McCULLY
Machine Shop

20 Vincent Rd. Quigamasis, N.B

E 2E1A1

Ph. 506-849-2213, 645-8090

emvic - mineull@aiaa19591.org

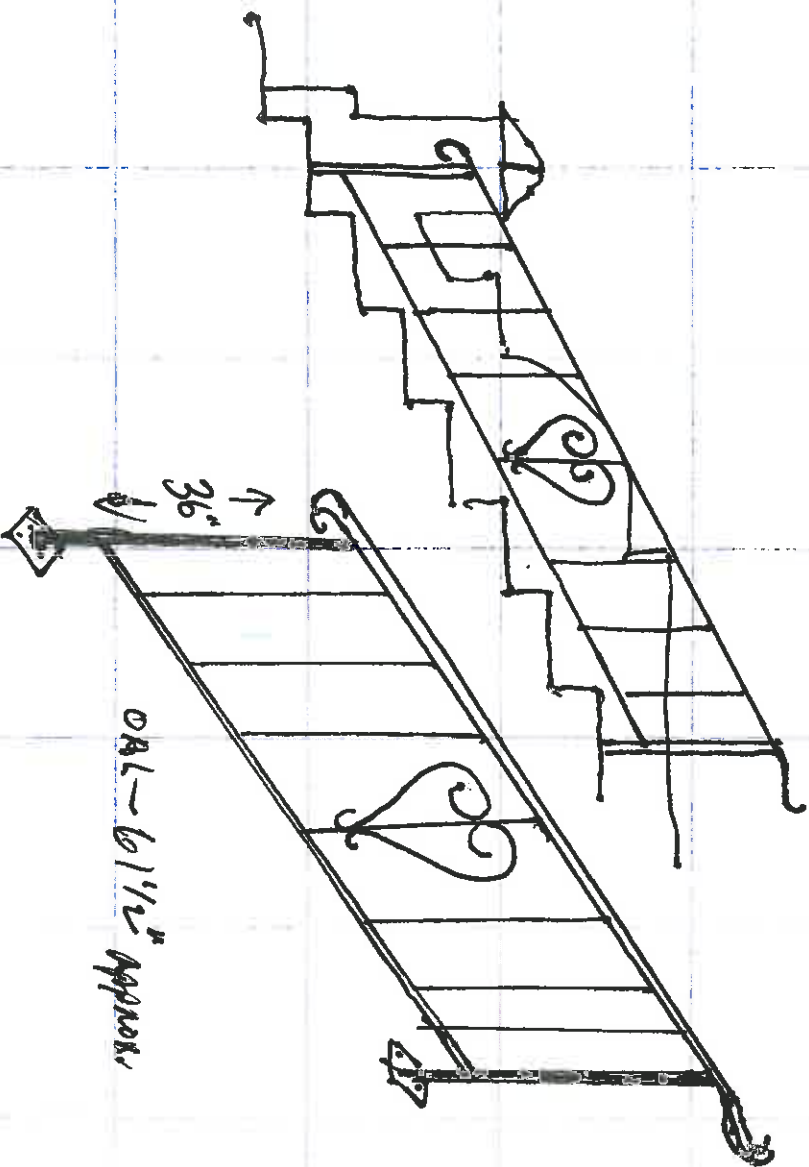

77 Dranges 87

Details

- All welded const.
- All steel
- Anchor pad
4 1/2 x 4 1/2 x 3/8
steel plate
- w - 4 - 3/4 x 3/8
corner brackets
each
- Black color
- Top hand rail
wid - 2"

ORL - 6 1/2" Approx.





Supplementary Information for Consideration of a Heritage Conservation Grant

The City of Saint John

Date: January 17th, 2014

To: Heritage Development Board

From: Alice Fudge, Heritage Officer

Application Number: [14-01] 77 Orange Street

Name: Bob McVicar

Mailing Address: 34 Orange Street, Saint John, NB

Postal Code: E2L 1M1

Description of Work: Installation of new steel hand railings at front entry.

Project Estimate: \$1500.00

Heritage Area: Orange Street

Conservation Plan: Yes No

Grant Type: Heritage Conservation Grant

Applicable Funding Ratio: 15%

Eligible Grant Funding Amount: \$225.00

Example of Motion:

Table the Heritage Conservation Grant for 15% up to a maximum of \$225.00 based on project estimates, for the installation of new hand railings at 77 Orange Street, *until the 2014 Heritage Grants program funding policies have been established.*



SAINT JOHN

P.O. Box 1971
Saint John, NB
Canada E2L 4L1

C.P. 1971
Saint John, N.-B.
Canada E2L 4L1

www.saintjohn.ca



The City of Saint John

**APPLICATION FOR A HERITAGE PERMIT
[CERTIFICATE OF APPROPRIATENESS]
2014-02**

**C/O: BOB McVICAR
78 ORANGE STREET
(PID 00007450)**

Date: January 17th, 2014

To: Heritage Development Board

From: Growth and Community Development Service

Prepared by: Alice C. Fudge
Heritage Officer

Approved by: Amy Poffenroth, P.Eng, MBA
Deputy Commissioner

SUBJECT

Application for a Heritage Permit [Certificate for Appropriateness] to install two new steel hand railings, painted black, on front entrance stair.

BACKGROUND

This three-storey residential building is located in the Orange Street Conservation Area; there is a Conservation Plan in place for this property.

To meet the Minimum Property Standards By-Law requirements, two hand rails must be installed at front entrance on either side of the sandstone steps for safety purposes.



SAINT JOHN

P.O. Box 1971
Saint John, NB
Canada E2L 4L1

C.P. 1971
Saint John, N.-B.
Canada E2L 4L1

www.saintjohn.ca

6

ANALYSIS

This is a Rehabilitation project and Standards I through XII of Section 8(2) of the *Saint John Heritage Conservation Areas By-law* apply. The proposed hand railings address the safety concerns of the owner and serve to rehabilitate the building.

Where a new element is introduced, Standard (XI) recommends that such a new addition to a historic place conserve its heritage value and character-defining elements and be visually compatible and respectful of the historic place. The material and traditional design of the railings meet this standard. The steel rails are to be painted black. The railing post base plates shall be fixed to the stair treads by set-in-place bolts.

Standard (I) recommends that all intact or repairable character-defining elements be conserved.

RECOMENDATION

Approve Heritage Permit [Certificate of Appropriateness] for the installation of two new steel hand railings, painted black, on front entrance stair of 78 Orange Street.

Manual Welding
Machine Shop

20 Vincent Rd. Quispamsis N.B.
CANADA

Ph - (506) 849-2213 645-8090

Email - mmwelding@iaa.ca 3591.0rc

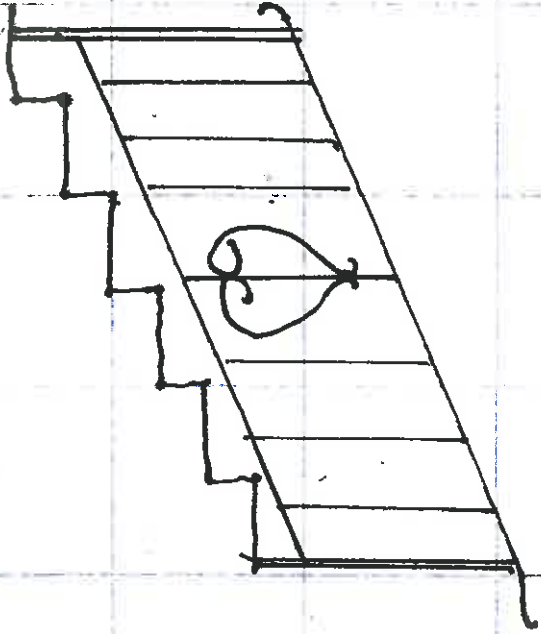

78 Orange St

- DETAILS
All Steel
welded const

- Anchor Pads
4 1/2" x 1 1/2" x 3/8"
4 - 3 1/2" x 3/8"
- Black in color
- Top Hand
KML 2" width

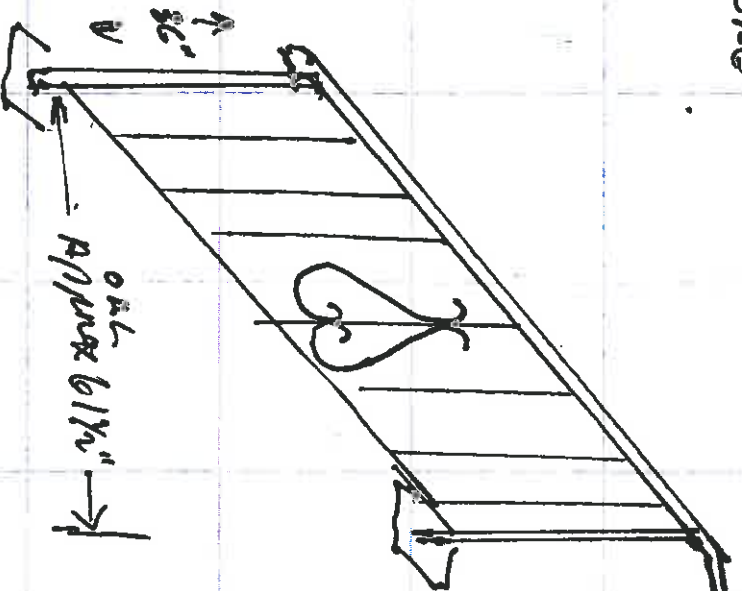





Supplementary Information for Consideration of a Heritage Conservation Grant

The City of Saint John
Date:

January 17th, 2014

To: Heritage Development Board

From: Alice Fudge, Heritage Officer

Application Number: [14-02] 78 Orange Street

Name: Bob McVicar

Mailing Address: 34 Orange Street, Saint John, NB

Postal Code: E2L 1M1

Description of Work: Installation of new steel hand railings at front entry.

Project Estimate: \$1500.00

Heritage Area: Orange Street

Conservation Plan: Yes No

Grant Type: Heritage Conservation Grant

Applicable Funding Ratio: 15%

Eligible Grant Funding Amount: \$225.00

Example of Motion:

Table the Heritage Conservation Grant for 15% up to a maximum of \$225.00 based on project estimates, for the installation of new hand railings at 78 Orange Street, *until the 2014 Heritage Grants program funding policies have been established.*



SAINT JOHN

P.O. Box 1971
Saint John, NB
Canada E2L 4L1

C.P. 1971
Saint John, N.-B.
Canada E2L 4L1

www.saintjohn.ca